



# GARAYE

G A R A Y E E N E R G Y

# CONTENTS



**Company Profile**



**R&D Capability**



**Product Platform**



**Strategic Target**





# Part 01



# Company Profile

- About Us
- Company Honors
- Market Distribution
- Mission, Vision, Value





# Company Profile



## Glory energy (Shenzhen) Co., Ltd.

We are a high-tech enterprise mainly engaged in the R&D, design, production and sales of lithium battery management system, lithium battery energy storage system, lithium battery module and battery monitoring system.

The company has become one of the lithium battery energy storage system, Micro grid energy storage, UPS lithium battery and LiFePo<sub>4</sub> deep cycle battery leading manufacturers in the field of Lithium-ion energy in China.

Committed to providing customers with safety , light and durable green energy products





# Company Profile



Continuous independent innovation ability



Excellent overall development and design ability of lithium-ion battery module



Excellent cost control ability



Reasonable business positioning



High-quality customer resources

The company has become one of the lithium battery system application manufacturers with the strongest design ability, the most complete supporting ability and the most product series in the field of lithium-ion energy in China.



## Four Product Platforms



Lithium Battery Energy Storage System



UPS Lithium Battery



Micro Grid Energy Storage



LiFePo<sub>4</sub> Deep Cycle Battery



# Company Honors

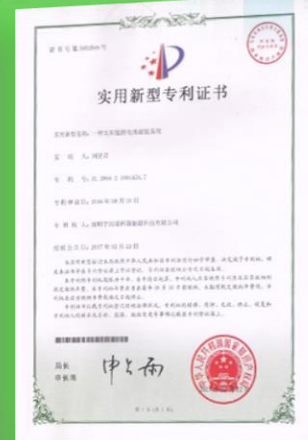
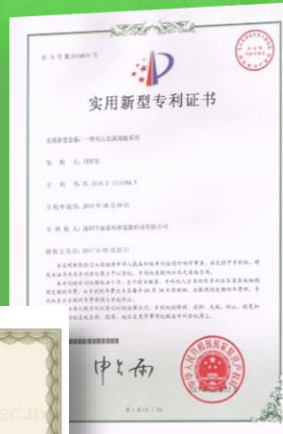
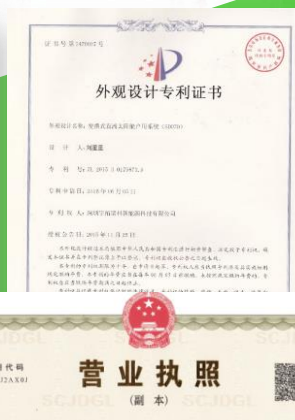
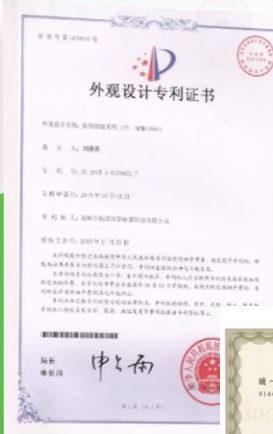
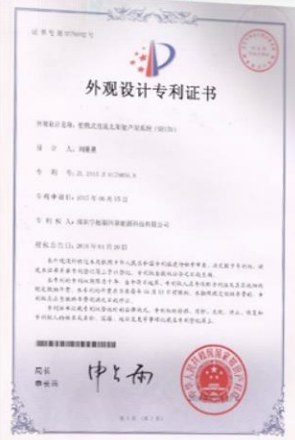
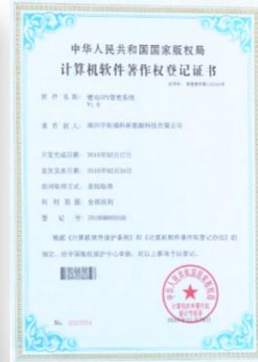
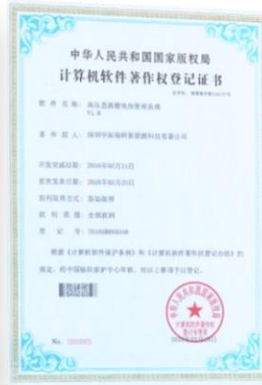





# Vision, Mission, Value

## Vision

Continuous innovation to create first-class energy products and create sustainable energy products and business opportunities for consumers and partners.

## Value

Fairness, justice, tolerance, and integrity.

## Mission

- Based on the business purpose of providing customers with safe, reliable and stable energy products and services, creating good returns for shareholders, avowing together with partners.
- providing space for employees to develop, and creating public value for society, we actively provide employees, stakeholders such as customers, partners, and society assume social responsibility, and strive to achieve harmonious development between the company and customers. Share holders, partners employees and society, so that more people can lead a better quality of life.

## Purpose

We are committed to the business philosophy of "customer first, people-oriented, quality, technology leadership, and sustainable profit growth" to create a trusted brand image and a respectable public image.

## Spirit

Diligence, hard work, innovation, win-win.





# Market Distribution

## Global Market Distribution

The company has sales offices and product centers in Shenzhen Nanshan district, Europe, the United States, South Africa, Southeast Asia, etc., which can provide solutions and services for local customers quickly and effectively. The main partners are Indonesia Telkomsel, Thailand Truemove, Vietnam Mobiphone, South Africa MTN America Graham, America Lithiumhub, Germany ETSOLAR, Netherlands Newelectric, South Africa SolarEPC, Australia Master Instrument so on.

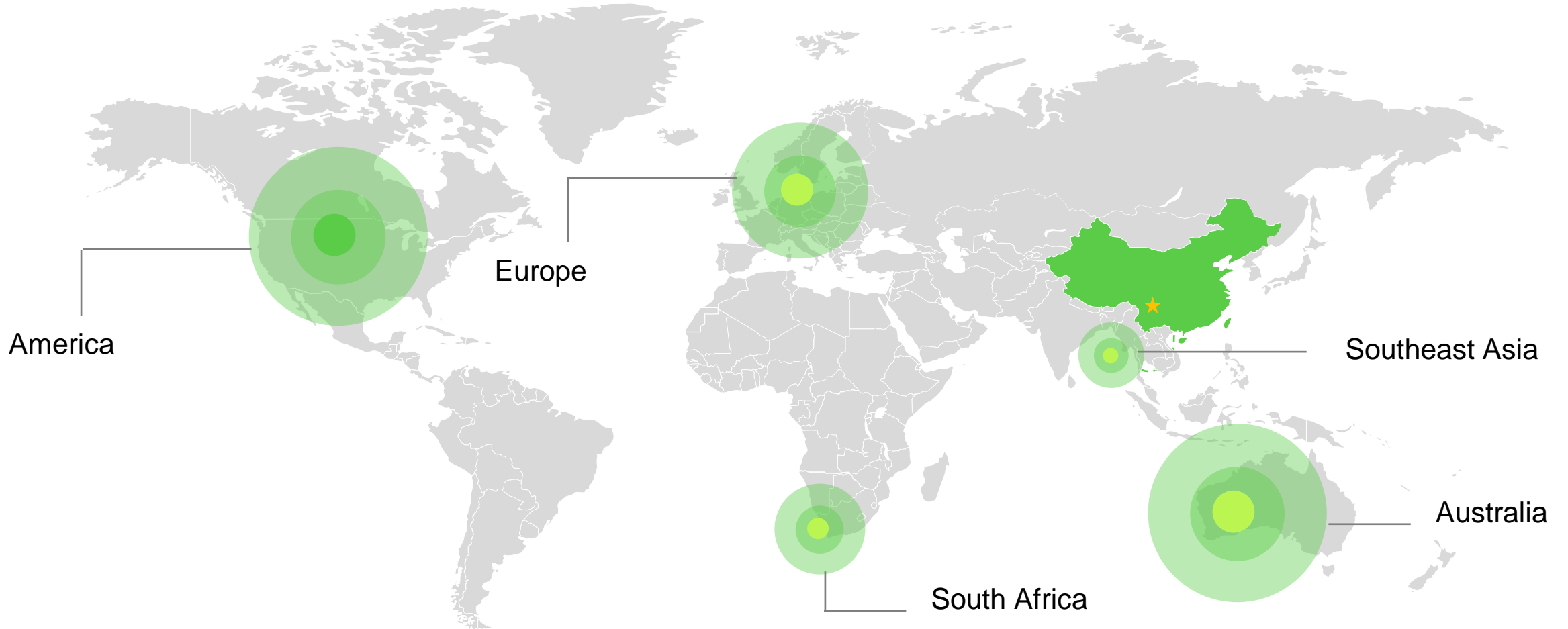



# Part 02



# R&D Capability

- R&D System
- Design Validation
- Experiment Condition
- Design Capacity



# R&D System

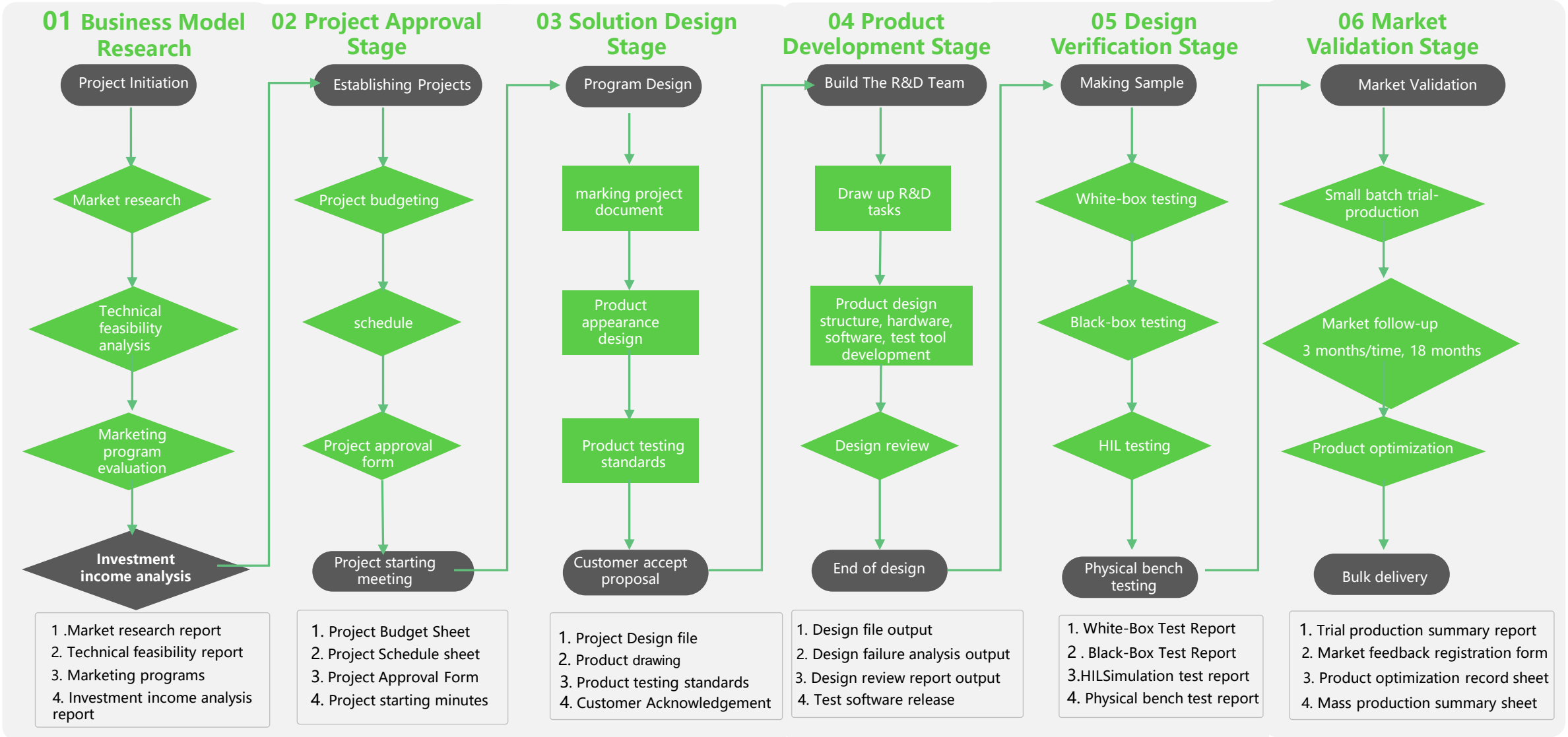





# Verification System

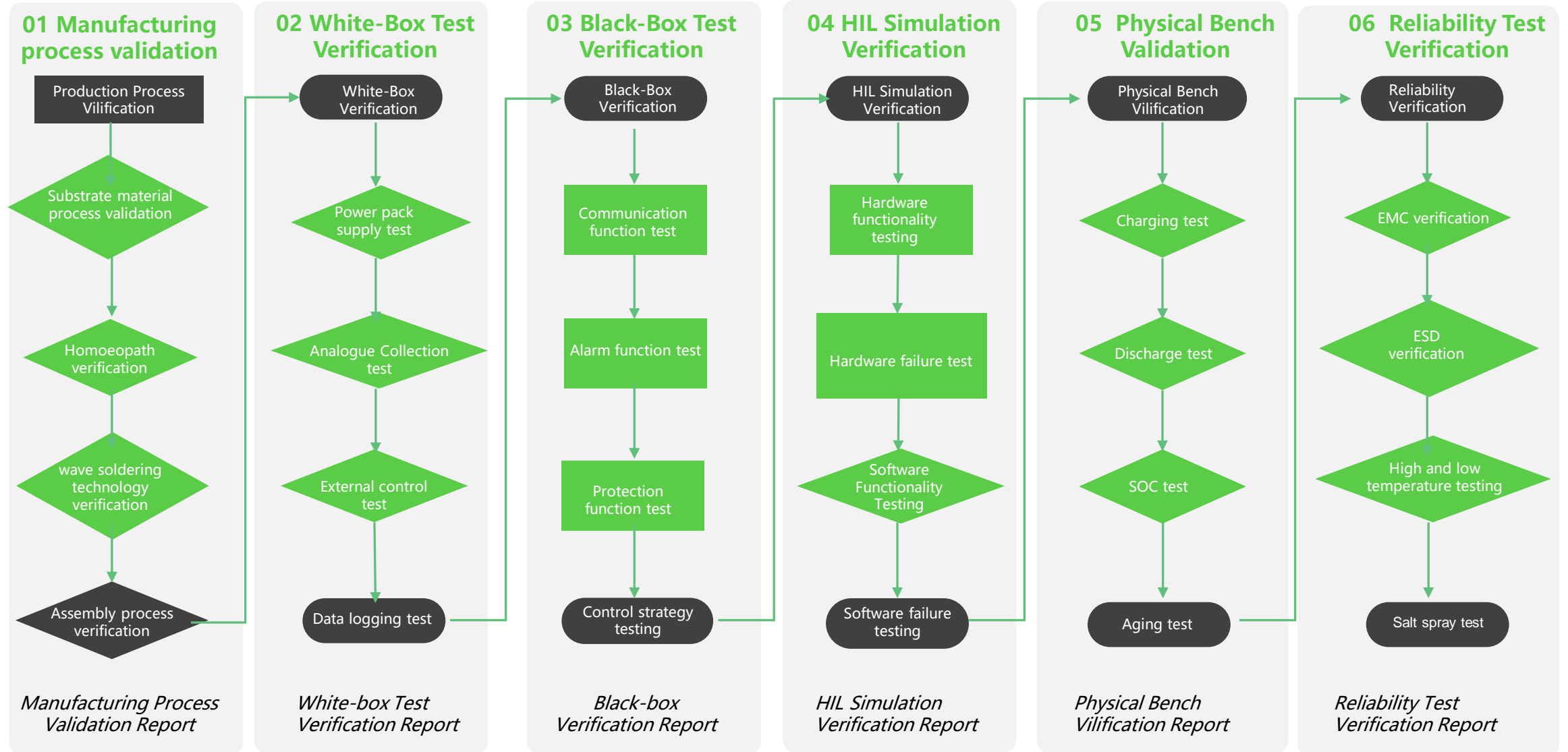

# Experimental Conditions

We have built our cell lab, hardware lab, software lab, system simulation lab, environment lab, and reliability lab to ensure the design verification basis in the R&D process.

Cell performance test

Cell safety test

Hardware functionality test

System environment test

System aging test

Software module testing and control strategy simulation testing

System performance testing and system control logic testing



Hardware Lab



Software Lab



Cell Lab



System Simulation Lab



Environment Lab



Reliability Lab





# Design Capacity



Intelligent Communication Module



FC Series Module BMS



Li-ion Replacement Module BMS

EMS

Energy Storage BMS  
All-in-one Machine



Off-grid And  
Household System  
Main Control Module





# Design Capacity

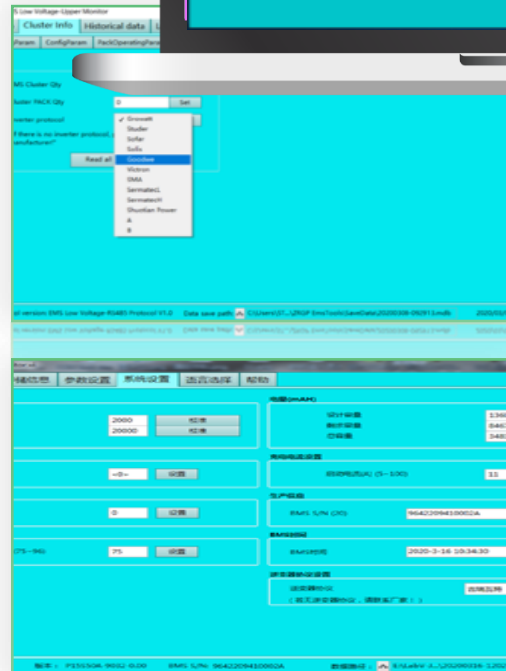
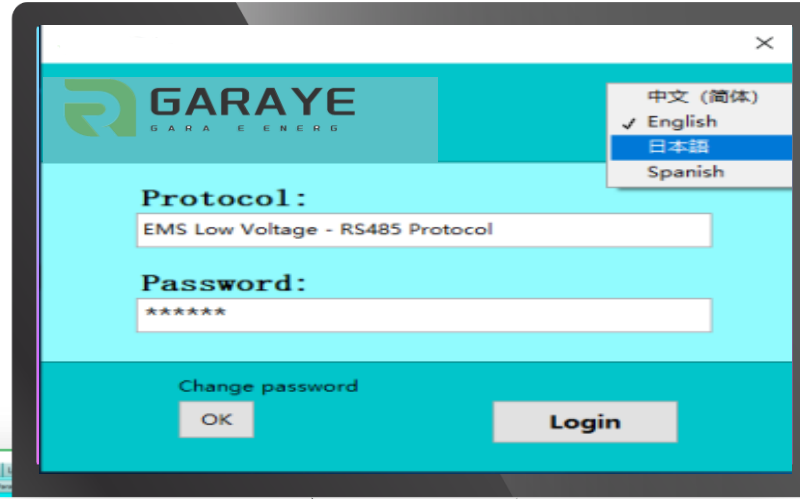





# Applications

- Lithium Battery Energy Storage System
- Micro Grid Energy Storage
- LiFePo4 Deep Cycle Battery
- UPS Lithium Battery

# Lithium Battery Energy Storage System

Battery module

Intelligent BMS

Master control

Structure assembly

- A system can accommodate up to 10 module, and it is supported that paralleling up to 15 system.
- The battery capacity can be freely adapted in the interval 5kWh to 768kWh according to the needs of users, and the output power supports 12kW-144kW.

Master control matches with mainstream brands of the global photovoltaic inverter:  
SMA\Victron\Studer\GoodWe\Growatt  
\Solis\Sofarsolar (Free communication)

## Compatible Inverter Brand



S20 Series



FC Series



X20 Series



M50 Series





# Power Base S20

LiFePo<sub>4</sub> Battery

Intelligent BMS

Structure Assembly

- X1 energy module can accommodate up to 5.12 Kwh capacity and parallel up to 63 module.
- Freely adapted in the interval 5.12kWh to 322kWh according to the needs of users.
- Matches with mainstream brands of the global photovoltaic inverter.

## Wall-mount mode

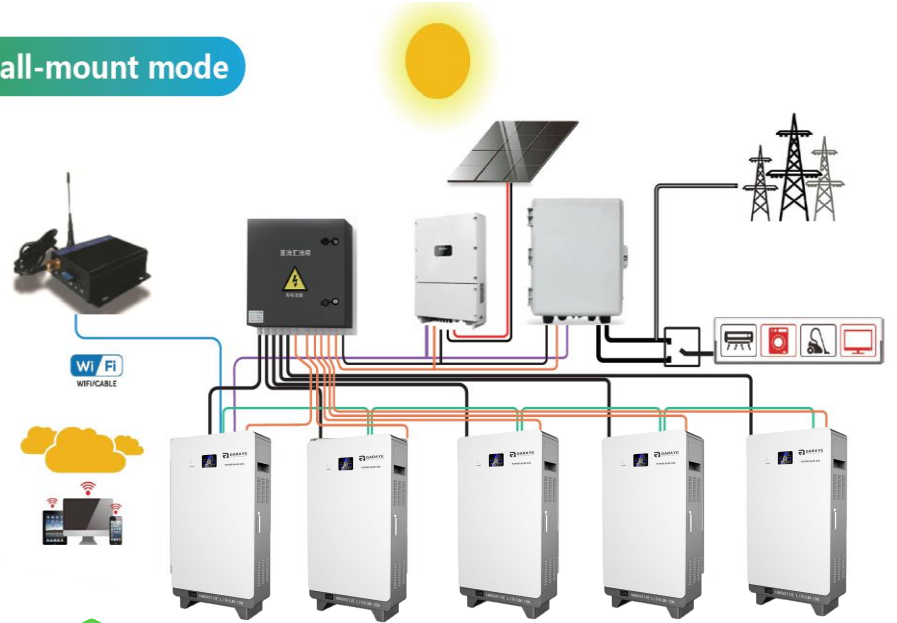

## Features

- Good extensibility, supporting 63 modules to be used in parallel.
- Good adaptability and can be adapted to the global mainstream photovoltaic inverters.
- Support expansion and power expansion.
- Wall-mounted installation, quick installation, and reduce the occupied area.

## Description

- Use LiFePo<sub>4</sub> cells with high safety, good reliability and long cycle life.
- The system has a built-in intelligent BMS to protect the battery system in all aspects.
- The system comes with a display module, which can display the charge and discharge status and SOC.
- Cycle life ≥ 8000 times.





# Power Base FC

LiFePo<sub>4</sub> Battery

Intelligent BMS

Structure Assembly

- FC energy module can accommodate up to 5.12 Kwh capacity and parallel up to 63 module.
- Freely adapted in the interval 5.12kWh to 322kWh according to the needs of users.
- Matches with mainstream brands of the global photovoltaic inverter.

## Description

- Use LiFePo<sub>4</sub> cells with high safety, good reliability and long cycle life.
- The system has a built-in intelligent BMS to protect the battery system in all aspects.
- The system comes with a display module, which can display the charge and discharge status and SOC.
- Cycle life ≥ 8000 times.

## Features

- Good extensibility, supporting 63 modules to be used in parallel.
- Good adaptability and can be adapted to the global mainstream photovoltaic inverters.
- Support capacity and power expansion.
- The standard 19-inch 3U size, which can be installed in the cabinet, wall-mounting and stacking by brackets.



Wall-mount mode

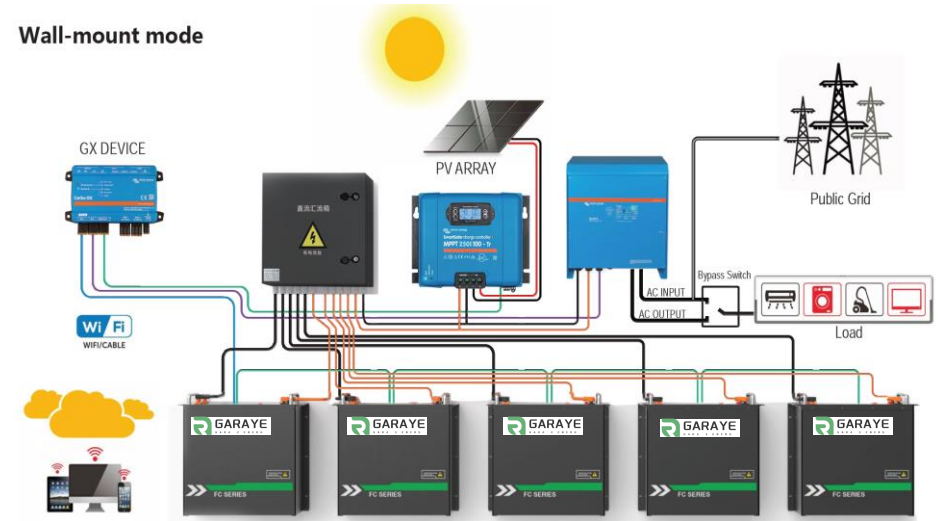

Stack mode

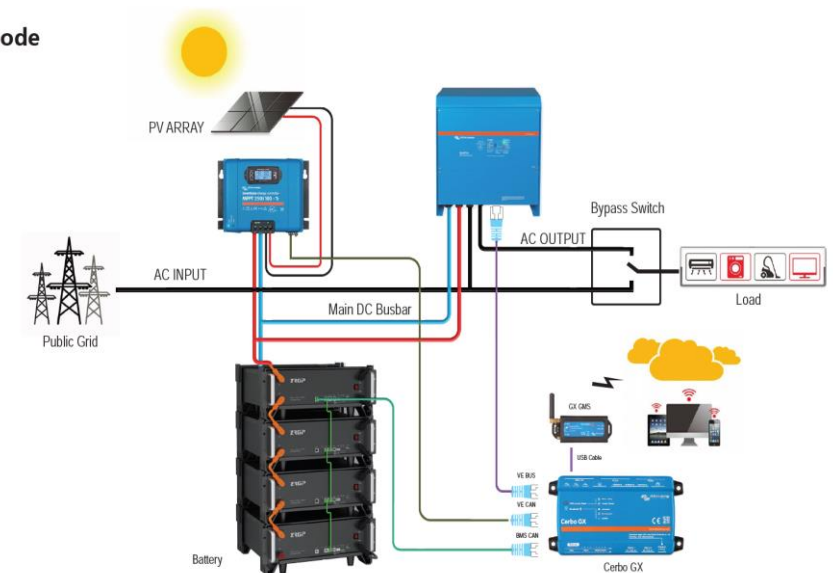



# Power Base X20 A

- LiFePo<sub>4</sub> Battery
- Intelligent BMS
- Master Control Module

## Structure Assembly

- Pro battery module can accommodate up to 5.12 Kwh capacity and parallel up to 10 module.
- Freely adapted in the interval 5.12kWh to 51.2kWh according to the needs of users.
- Matches with mainstream brands of the global photovoltaic inverter.



## Description

- Use LiFePo<sub>4</sub> cells with high safety, good reliability and long cycle life.
- The system has a built-in intelligent BMS to protect the battery system in all aspects.
- The system comes with a display module, which can display the charge and discharge status and SOC.
- Cycle life ≥ 8000 times.

Wall-mount mode

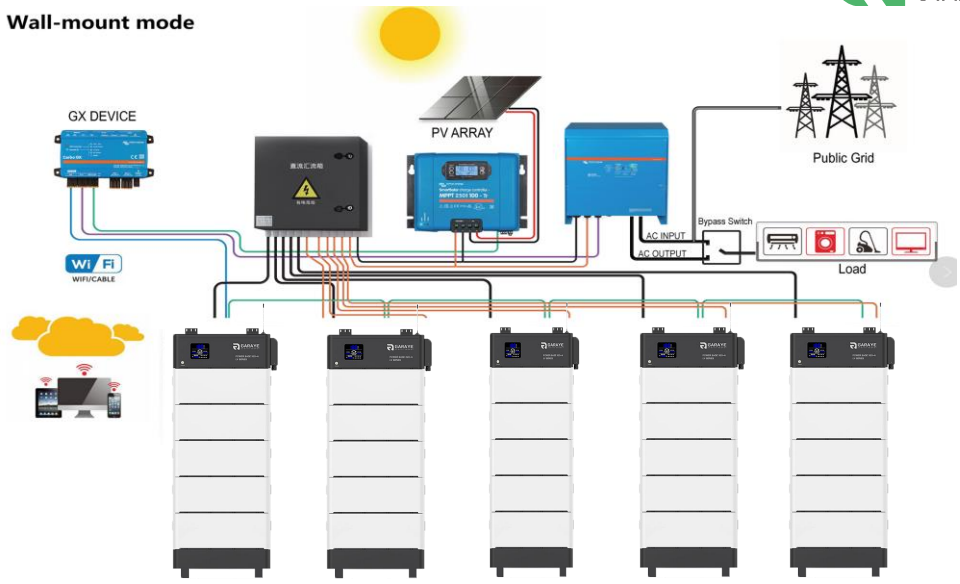

## Features

- Good extensibility, supporting 15 systems to be used in parallel.
- Meets 5.12kWh-768kWh capacity requirements according to user needs.
- A single system supports a load power of 12kW and has good adaptability, which can be adapted to global mainstream photovoltaic inverters.
- It supports capacity expansion and power expansion, and supports 144kW output through capacity expansion.
- With its own display screen, you can view system information and running status in real time.

# Power Base X20 B

- LiFePo<sub>4</sub> Battery
- Intelligent BMS
- Master Control Module

## Structure Assembly

- Pro battery module can accommodate up to 5.12 Kwh capacity and parallel up to 10 module.
- Freely adapted in the interval 5.12kWh to 51.2kWh according to the needs of users.
- Matches with mainstream brands of the global photovoltaic inverter.



## Description

- Use LiFePo<sub>4</sub> cells with high safety, good reliability and long cycle life.
- The system has a built-in intelligent BMS to protect the battery system in all aspects.
- The system comes with a display module, which can display the charge and discharge status and SOC.
- Cycle life ≥ 8000 times.

Wall-mount mode

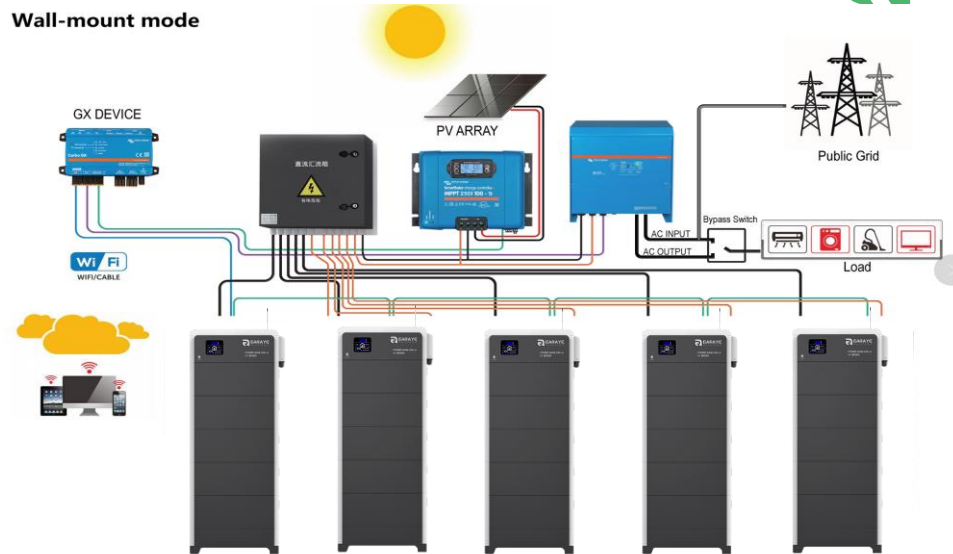

## Features

- Good extensibility, supporting 15 systems to be used in parallel.
- Meets 5.12kWh-768kWh capacity requirements according to user needs.
- A single system supports a load power of 12kW and has good adaptability, which can be adapted to global mainstream photovoltaic inverters.
- It supports capacity expansion and power expansion, and supports 144kW output through capacity expansion.
- With its own display screen, you can view system information and running status in real time.





# Power Base M50

LiFePo<sub>4</sub> Battery Module

Intelligent BMS

Structure Assembly



Mate battery module can accommodate up to 5.12 Kwh capacity and parallel up to 10 module.



Freely adapted in the interval 5.12kWh to 51.2kWh according to the needs of users.



Matches with mainstream brands of the global photovoltaic inverter.

## Wall-mount mode

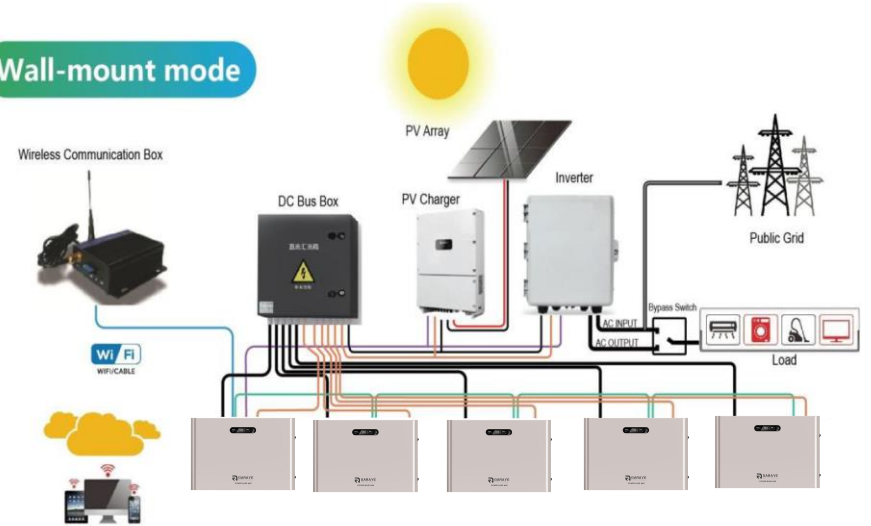

## Description



- Use LiFePo<sub>4</sub> cells with high safety, good reliability and long cycle life.
- The system has a built-in intelligent BMS to protect the battery system in all aspects.
- The system comes with a display module, which can display the charge and discharge status and SOC.
- Cycle life ≥ 8000 times.

## Features

- Good extensibility, supporting 15 systems to be used in parallel.
- It can meet 5.12kWh-768kWh capacity requirements according to user needs.
- A single system supports a load power of 12kW and has good adaptability, which can be adapted to global mainstream photovoltaic inverters.
- It supports capacity expansion and power expansion, and supports 144kW output through capacity expansion.
- Stacked installation, can be quickly stacked according to actual demand capacity.
- The protection grade is IP55, and it can be installed and used outdoors.
- Built-in display, you can view system information and running status in real time.



# Micro Grid Energy Storage



MAX15006D  
DC Energy Storage  
System

---

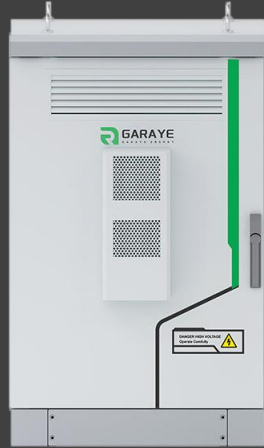

MAX15006D1  
DC Energy Storage  
System

---



MAX15050D  
DC Energy Storage  
System

---

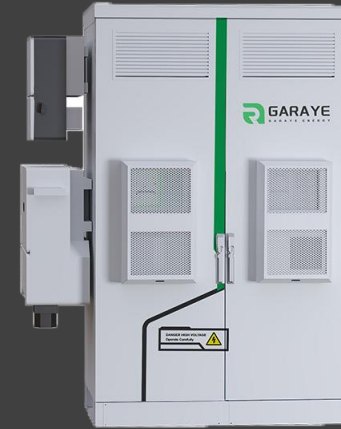

MAX15080A  
Off-grid/On-grid  
AIO Machine

---



Power Base Cube  
Micro Grid Energy  
Storage System

---





# MAX1506D1

## MAX1506D1 DC Energy Storage System

Battery Module

Master Control Module

Photo-Voltaic Controller

DCDC Battery

PV Converge Module

Structure Assembly

- Accommodate up to 5.12kWh capacity, up to 3 modules can be connected in parallel.
- Freely adapted in the interval of 5.12 Kwh-15.2 Kwh according to user needs.
- Matches with mainstream brands of the global photovoltaic inverter. (Omron, Yaskawa Electric, Mitsubishi Electric, etc.)

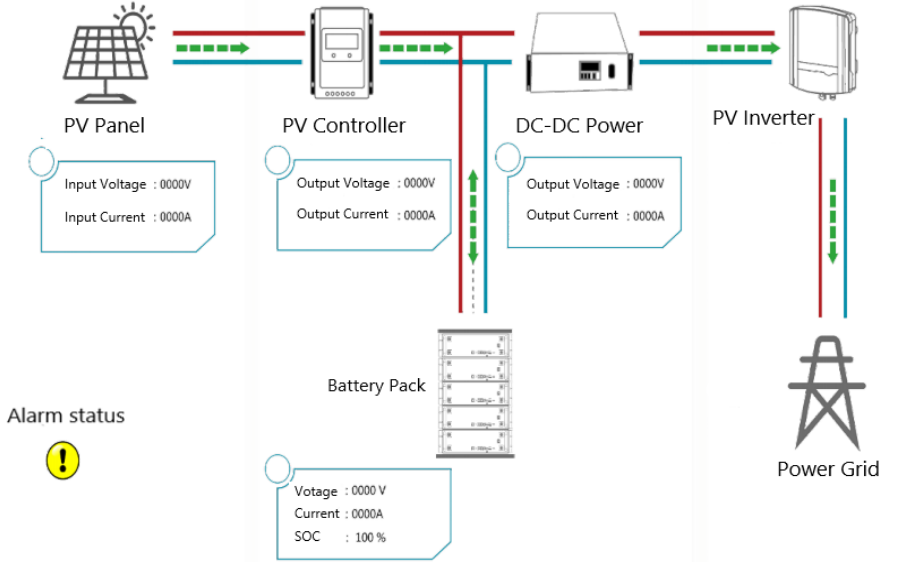

### Description

- Use LiFePo<sub>4</sub> cells with high safety, good reliability and long cycle life.
- The system has a built-in intelligent BMS to protect the battery system in all aspects.
- The system comes with a display module, which can display the charge and discharge status and SOC.
- Cycle life ≥ 8000 times, DOD > 80%.
- Through remote monitoring, the operating status of the battery system can be monitored at all times.
- Modular design, easy to install and easy to maintain.

### Features

- It has good extensibility and supports up to 20 systems in parallel.
- A single system supports a load power of 6KW and has good adaptability, which can be adapted to the global mainstream photovoltaic inverters.
- It supports capacity expansion and power expansion, and supports 120kW/300kWh output through capacity expansion.
- With air conditioner, it can be installed in cold/high temperature areas.
- The protection grade is IP55, which can be installed and used in coastal areas.



# MAX15050D

## MAX15050D DC Energy Storage System

Battery Module	Master Control Module	Photo-Voltaic Controller
DCDC Battery	PV Converge Module	Structure Assembly

- Can hold up to 150KWH capacity, up to 63 modules can be connected in parallel.
- Can be freely adapted according to user needs 150KWH-9450KWH.
- Matches with mainstream brands of the global photovoltaic inverter. (Omron, Yaskawa Electric, Mitsubishi Electric, etc.)

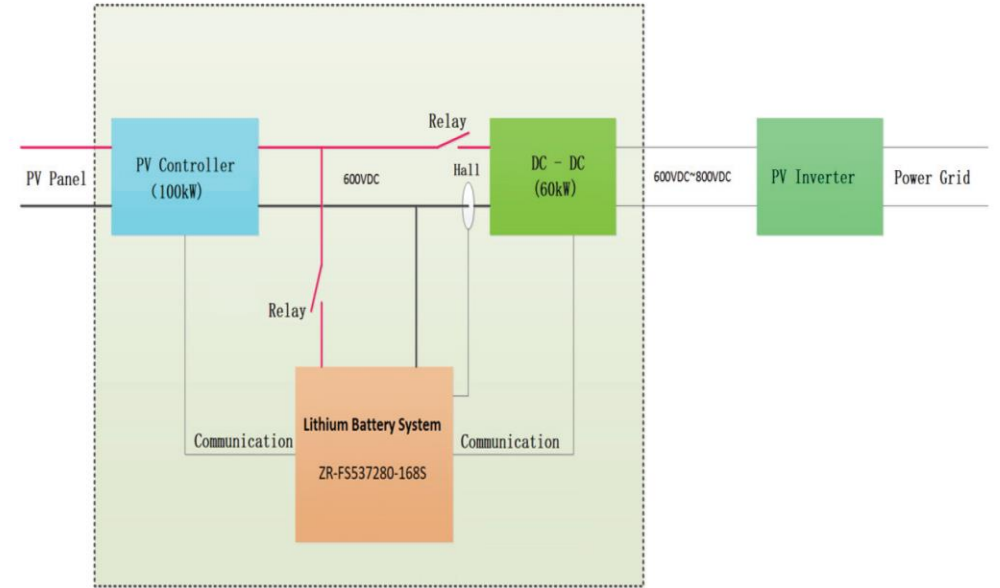

### Description

- Use LiFePo4 cells with high safety, good reliability and long cycle life.
- The system has a built-in intelligent BMS to protect the battery system in all aspects.
- The system comes with a display module, which can display the charge and discharge status and SOC.
- Cycle life ≥ 8000 times.
- Through remote monitoring, the operating status of the battery system can be monitored at all times.
- Modular design, easy to install and easy to maintain.

### Features

- Good extensibility, supporting 63 systems to be used in parallel.
- A single system supports a load power of 50KW and has good adaptability, which can be adapted to the world's mainstream photovoltaic inverters.
- Support expansion and power expansion, support 3MW/9.45MWH output through expansion mode.
- With air conditioner, it can be installed in cold/high temperature areas.
- With the high protection level, it meets the salt spray design.
- High voltage design, higher conversion efficiency.





# MAX15080A

## MAX15080A AC Energy Storage System

Battery Module

Master Control Module

Photo-Voltaic Controller

PCS

PV Converge Module

Structure Assembly

- System capacity is 150KWH, no need to add inverter.
- It can directly connect photovoltaics and the grid, achieve on-grid /off-grid connections so that it can meet their own consumption functions.

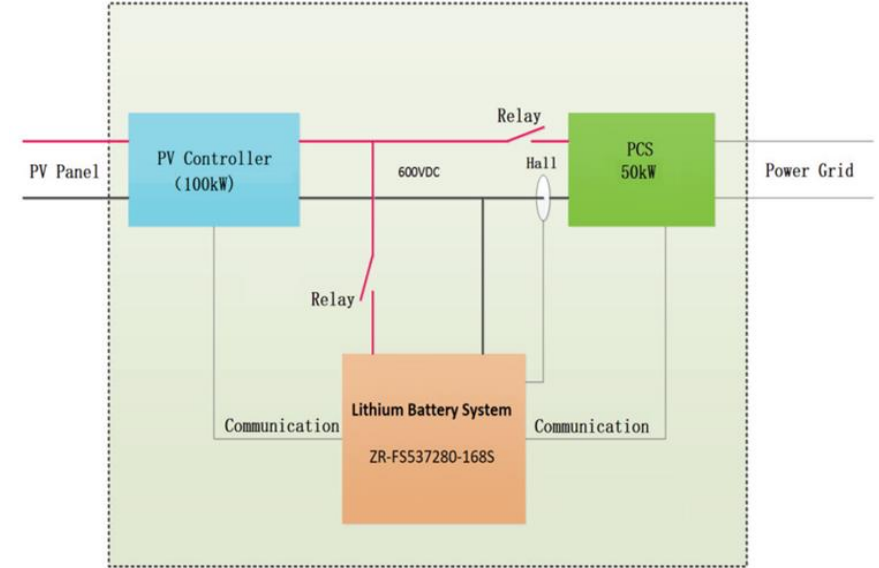

### Description

- Use LiFePo<sub>4</sub> cells with high safety, good reliability and long cycle life.
- The system has a built-in intelligent BMS to protect the battery system in all aspects.
- The system comes with a display module, which can display the charge and discharge status and SOC.
- Cycle life ≥ 8000 times.
- Modular design, easy to install and easy to maintain.

### Features

- It has good extensibility and supports parallel use of 20 systems.
- A single system supports a load power of 80KW, which can meet most industrial and commercial use scenarios.
- Support expansion and power expansion, and support 1.6MW output through expansion.
- Support local grid connection standards.
- Support expansion and power expansion.
- Intelligent control can realize the functions of matching load, smoothing photovoltaic, cutting peak and filling valley, etc.



# Power Base Cube

## Power Base Cube Micro-grid Energy Storage System

Battery Module    Master Control Module    Optical Storage Integrated Machine

EMS Module    Converge Module    Structure Assembly    Auxiliary System

- The battery capacity can reach 387kWh, and the output of the optical storage integrated machine can reach 100kW.
- The integrated container design is easy to install and maintain.

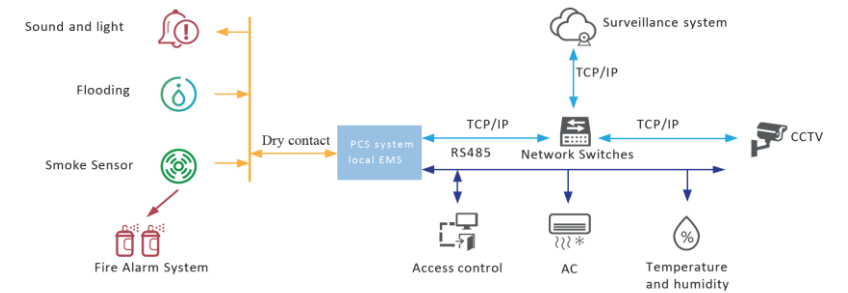
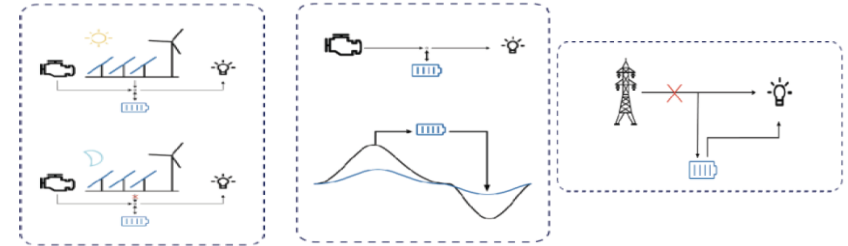

### Description

- Use LiFePo<sub>4</sub> cells with high safety, good reliability and long cycle life.
- The system has a built-in intelligent BMS to protect the battery system in all aspects.

### Features

- It has good extensibility and supports parallel use of multiple systems.
- According to user needs, the maximum capacity demand of 387kWh can be met.
- A single system supports a load power of 100kW and has good applicability, which can meet the needs of most industrial and commercial energy storage.
- Support capacity expansion and power expansion, and support 500kW output through capacity expansion.

- The system comes with a display module, which can display the charge and discharge status and SOC.
- Cycle life ≥ 8000 times.

- Conform to local grid connection standards.
- The integrated container design is easy to install and maintain.
- The battery capacity and power output can be changed according to customer needs.
- The container design meets the harsh outdoor installation requirements.
- Intelligent control can realize the functions of matching load, smoothing photovoltaic, peak shaving and valley filling.





# LiFePo4 Deep Cycle Battery

## Support parallel expansion capacity

Support series connection to 48V system, and can meet 4 parallel use.

## All series support 12V standard module size

The size of the interface is the same as that of lead acid, which is a perfect replacement.

## Built-in BMS management system in standard battery

With safe and reliable overcharge, overdischarge, overcurrent, and short circuit protection functions, customers can choose whether to configure the Bluetooth function according to their needs.

## Bluetooth function

The APP supports Android and Apple systems. Install the APP on the smart terminal to monitor and modify operating parameters.





# Monitoring Of LiFePo4 Deep Cycle Battery

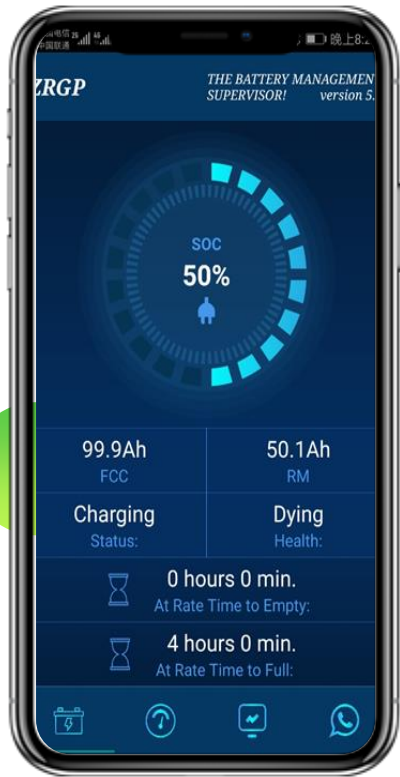





# LiFePo4 Deep Cycle Battery Series



ZR-LFP12007



ZR-LFP12010



ZR-LFP12020



ZR-LFP12050



ZR-LFP12100



ZR-LFP12150



ZR-LFP12200



ZR-LFP24100



# UPS Lithium Battery

AC DPS



DC DPS



Uranus lithium battery  
energy storage system



Venus lithium battery  
energy storage system



# AC DPS

Item	ACDPS0604A ACDPS0606A	ACDPS0604B ACDPS0606B
Component	Power module, Machine Frame, Battery module, Bypass module	
Input Output	Dual 220VAC input Dual 220VAC output	Single 220VAC input Dual 220VAC output
Configuration	6KW/6KVA, 10-30Ah Lithium Battery	
Efficiency	AC mode $\geq$ 95% Battery mode $\geq$ 94.5%	
Feature	AC online	
Communication	RS485, Ethernet	
Dimension	4U, 6U	

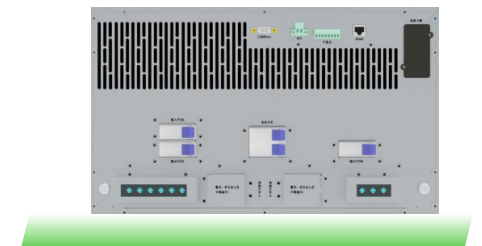
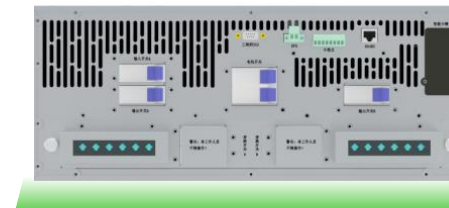





# AC DPS Standard Deployment Scheme

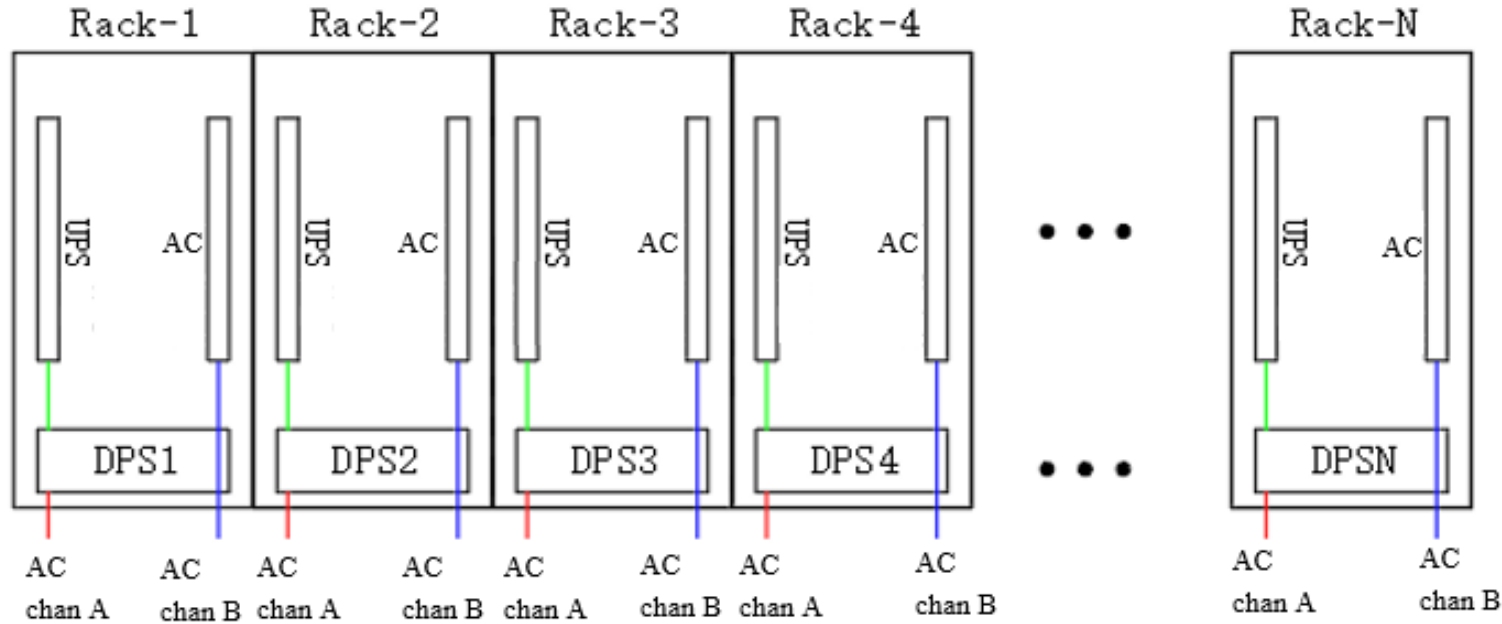

AC outputs of channel A&B from the array cabinet are connected to the DPS at the same time, DPS outputs two channels of power source to PDU.

- One channel is for backup to supply power after blackout through inverter.
- The other channel is AC, DPS is just for detection and management.



# AC DPS Highly Reliable Deployment Scheme

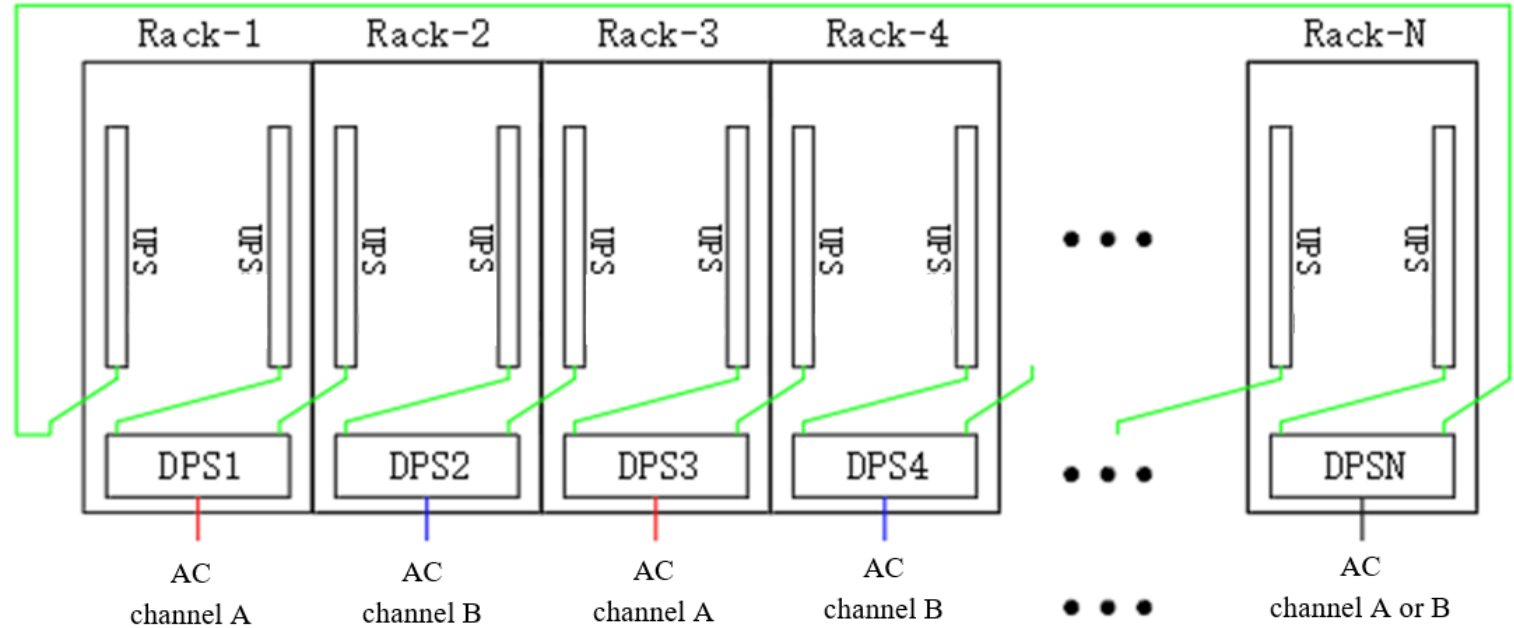
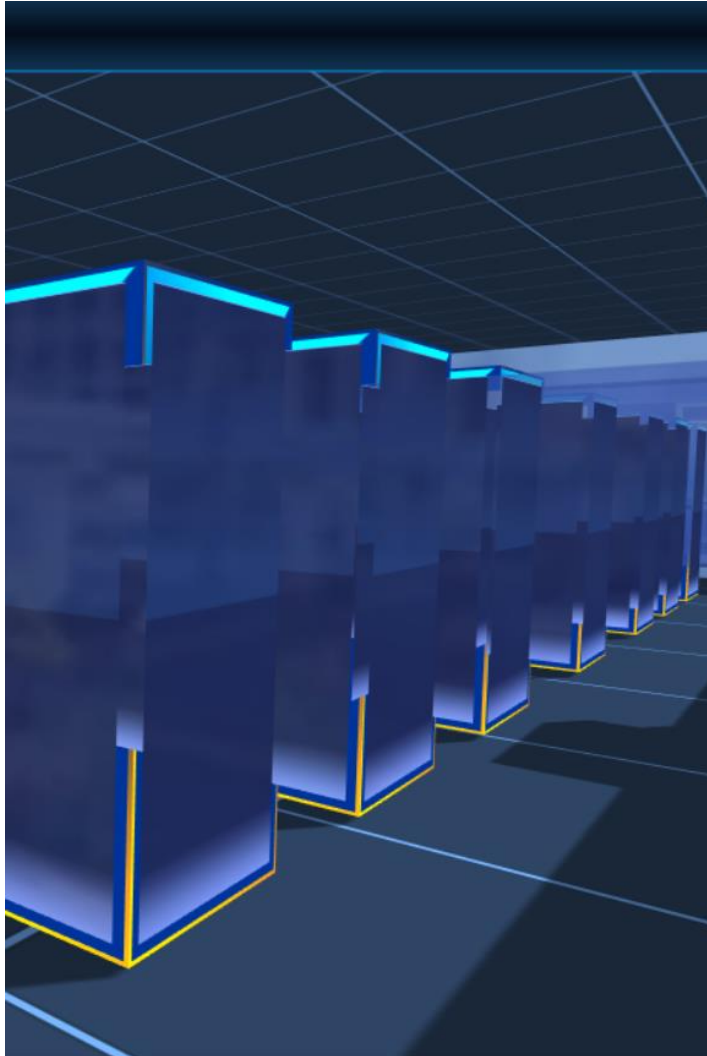

Outputs from the array cabinet

Channel A is connected with 1,3,5.....odd number cabinet.

Channel B is connected with 2,4,6.....even number cabinet.

**DPS outputs two channels of power source to PDU, both of them can be used as backup.**

- One chan supplies for this cabinet.
- The other one supplies for adjacent cabinets.



# HVDC DPS

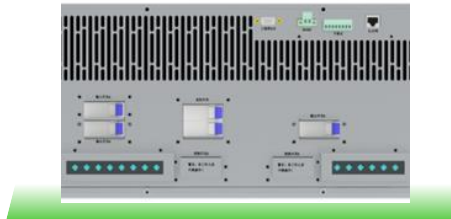

Item	DCDPS0903E DCDPS0905E	DCDPS0903F DCDPS0903F
Component	Rectifier Module, Shell, Battery Module, Bypass Module	
Input Output	Dual-input , Dual-output Single-input , Dual-output	
Configuration	9kW(3kW*3), 230V 10-30AH Lithium Battery	
Efficiency	Overall Efficiency≥95%	
Characteristic	Input: 0.99	
Communication	RS485, Ethernet	
Dimension	3U, 5U	
Power Compatibility	Comply with Standard HVDC power supply, compatible with Standard UPS of IT equipment	





# DC DPS Standard Deployment Scheme

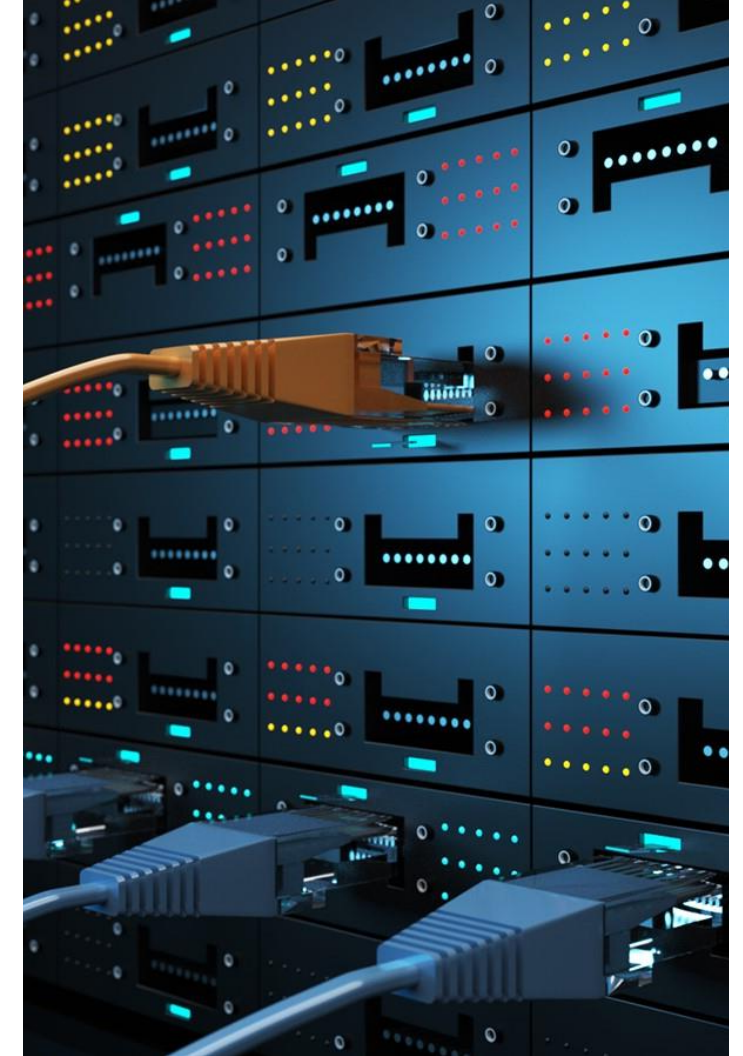
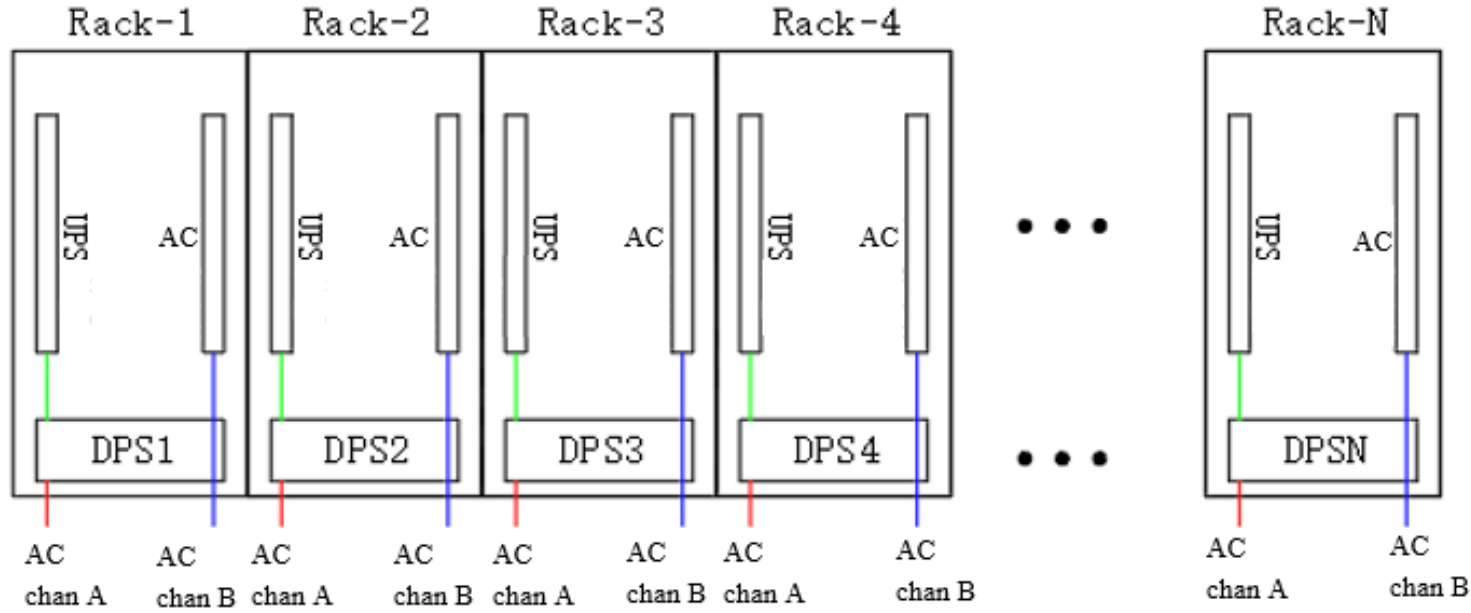

AC outputs of channel A&B from the array cabinet are connected to the DPS at the same time, DPS outputs two channels of power source to PDU.

- One channel is for backup to supply power after blackout through battery.
- The other channel is AC, DPS is just for detection and management.



# DC DPS Highly Reliable Deployment Scheme

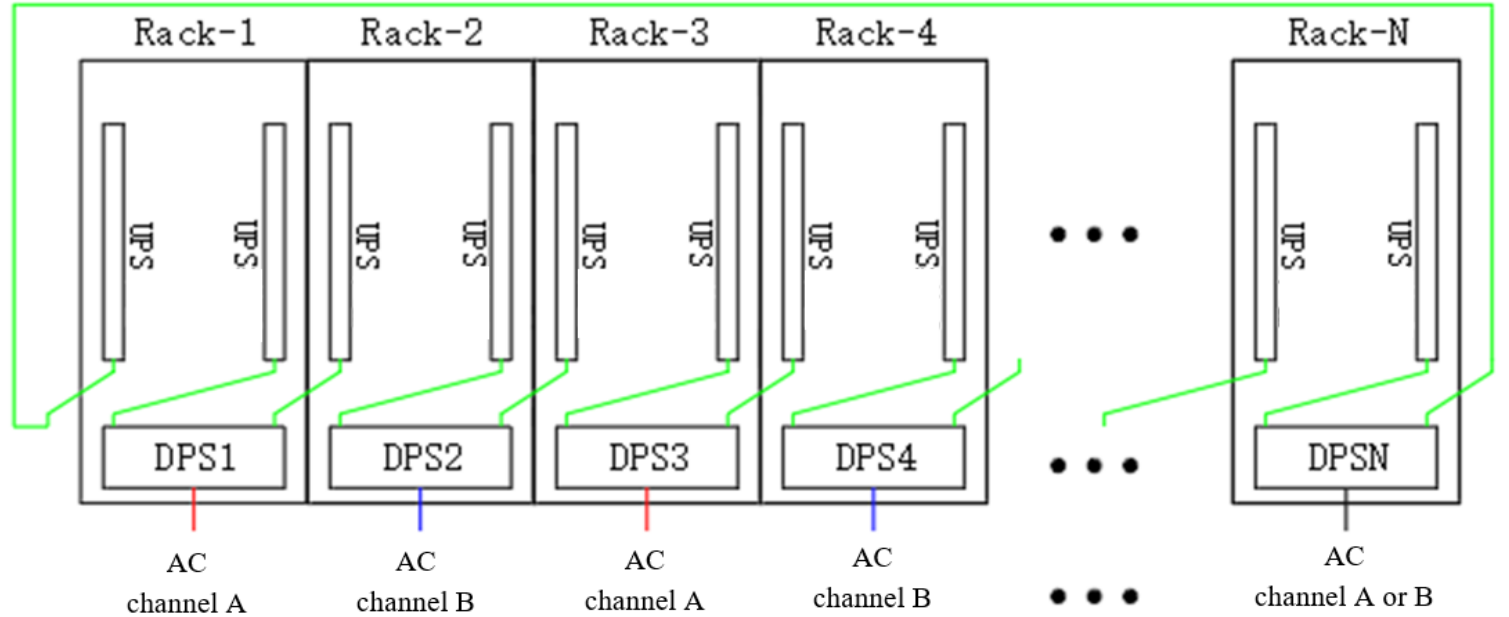

Outputs from the array cabinet

Channel A is connected with 1,3,5.....odd number cabinet.

Channel B is connected with 2,4,6.....even number cabinet.

**DPS outputs two channels of power source to PDU, both of them can be used as backup.**

- One chan supplies for this cabinet.
- The other one supplies for adjacent cabinets.

# Veunus Lithium Battery Cabinet

## Product Description

- Veunus series lithium batteries are developed specially for modular UPS, the internal LFP batteries has high safety and long cycle life.
- Nominal voltage is 512V, can be expanded to  $\pm 256V$  by changing the mode of connection.
- Nominal Energy is 51.2KWH.
- Intelligent built-in BMS for managing charging and discharging.
- CAN, RS485 communication outputs to communicate with external UPS conveniently.

## Product Features

- High safety, cycle life 3500 times,  $DOD \geq 80\%$ .
- High discharge C-rate, supports 1C charge and discharge.
- Wide temperature range, charge temperature  $0^{\circ}C-55^{\circ}C$ , discharge temperature  $20^{\circ}C-55^{\circ}C$ .
- BCU system configuration management system supports battery cabinet mix of old and new, lithium and lead-acid mix.

No.	Items	Parameters
1	Nominal Voltage	$\pm 256V$ 51.2kWh      512V 51.2kWh
2	Voltage	Recommend Charging $\pm 284V$ 568V
		Max. Charging $\pm 292V$ 584V
		Discharge Cut-off $\pm 240V$ 480V
3	Main Control Module	ZR-MC500-150M
4	Battery Module Type	ZR-FE48100-1635R1
5	Battery Module QTY	10
6	Module Configuration	160S1P
7	Nominal Capacity	100Ah
8	Nominal Energy	51.2kWh
9	Chemistry	LiFePo4
10	Current	Max. Charging      100A
		Max. Discharging      100A
		Peak for 30s      150A
11	Weight (Approx.)	500kg
12	Dimensions (L*H*W))	600*2020*600 mm
13	Communication	RS485, CAN
14	Cycle Life	3500 times@80%DOD
15	Designed Calendar Life	$\geq 10$ years
16	Safety Function	Over-charge, Over-discharge, Over-current, Low/High-temperature, Low-voltage, Short-circuit Protections
17	Parallel Capability	Maximum 10 units (Recommended 6 units)
18	Cable Outlet	Top-back

$\pm 256V$

512V





# Uranus Lithium Battery Cabinet

## Product Description

- Uranus series lithium batteries are developed specially for modular UPS, the internal LFP batteries has high safety and long cycle life.
- Nominal voltage is 512V, can be expanded to  $\pm 256V$  by changing the mode of connection.
- Nominal Energy is 51.2KWH.
- Intelligent built-in BMS for managing charging and discharging.
- CAN, RS485 communication outputs to communicate with external UPS conveniently.

## Product Features

- High safety, cycle life 3500 times,  $DOD \geq 80\%$ .
- High discharge C-rate, supports 5C charge and discharge, maximum discharge C-rate up to 204KW.
- Wide temperature range, charge temperature  $0^{\circ}C - 55^{\circ}C$ , discharge temperature  $20^{\circ}C - 55^{\circ}C$ .
- BCU system configuration management system supports battery cabinet mix of old and new, lithium and lead-acid mix.

No.	Items	Parameters		
1	Model	PowerBase Uranus 20	PowerBase Uranus 40	
2	Main Control Module	ZR-MIN-R0		
3	Battery Module Type	ZR-FE4840-1630R1	ZR-FE4880-1630R1	
4	Module Configuration	10S1P		
5	Nominal Capacity	40Ah	80Ah	
6	Nominal Energy	20.48kWh	40.96kWh	
7	Chemistry	LiFePo4		
8	Voltage	Nominal	512V $\pm$ 250V	
		Recommend Charging	568V	
		Max. Charging	584V	
		Discharge Cut-off	480V	
9	Current	Max. Charging	40A	80A
		Max. Discharging	200A	400A
10	Weight (Approx.)	470kg	650kg	
11	Dimensions (W*D*H)	600*870*2000 mm		
12	Communication	RS485, CAN, SNMP		
13	Cycle Life	$\geq 3500$ times		
14	Designed Calendar Life	$\geq 10$ years		
15	Safety Function	Over-charge, Over-discharge, Over-current, Low/High-temperature, Low-voltage, Short-circuit Protections		
16	Parallel Capability	Maximum 10 units (Recommended 6 units)		
17	Cable Outlet	Top-back		





## Part 04



# Strategic Target

- Market Goal
- Technical Direction
- Quality Goal
- Development Goal



# Market Goal

Target Market

Europe, America, Japan, South Africa

2020 2021 2022 2023 2024 2025

Total

80 million

180 million

360 million

720 million

1500 million

Sales Target

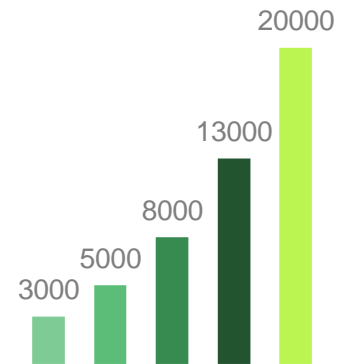
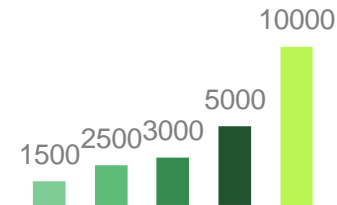
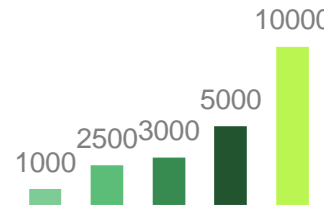
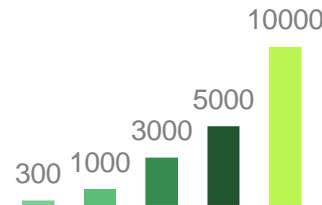
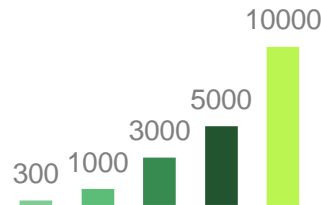

Business Model

Agent

Agent

Agent

Agent

Agent

Agent

Executive Department

Department 1

Department 2

Department 3

Subsidiary in Japan





# Technical Direction



## BMS

Manage and maintain the entire cycle life of lithium batteries through AI technology.

## BMS self-maintenance function

Adjust the battery management strategy based on the analysis and estimation of the actual operating data to achieve the function of safe using and extended service life.

## IoT function

Make energy storage system interacted with a variety of user terminals, manage and maintain the entire cycle life of lithium batteries through IoT technology.



## Optimize the overall solution continuously

We are committed to the application technology research of lithium batteries in data centers, energy storage systems, micro grid energy storage, UPS lithium battery and LiFePo4 deep cycle batteries.

## Transform the latest cell technology into market products

Establish strategic partnerships with industry-leading brands of cell companies to transform the latest battery cell technology into market products.

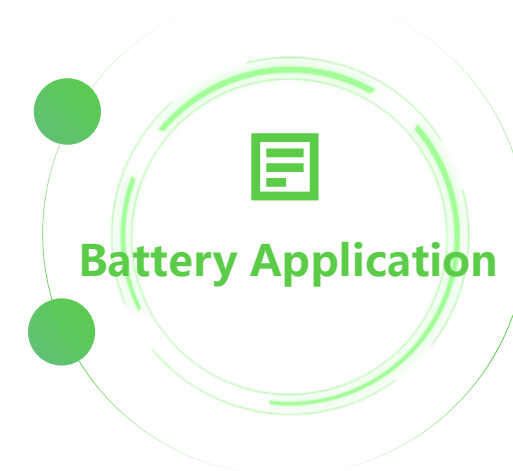

# Quality Goal

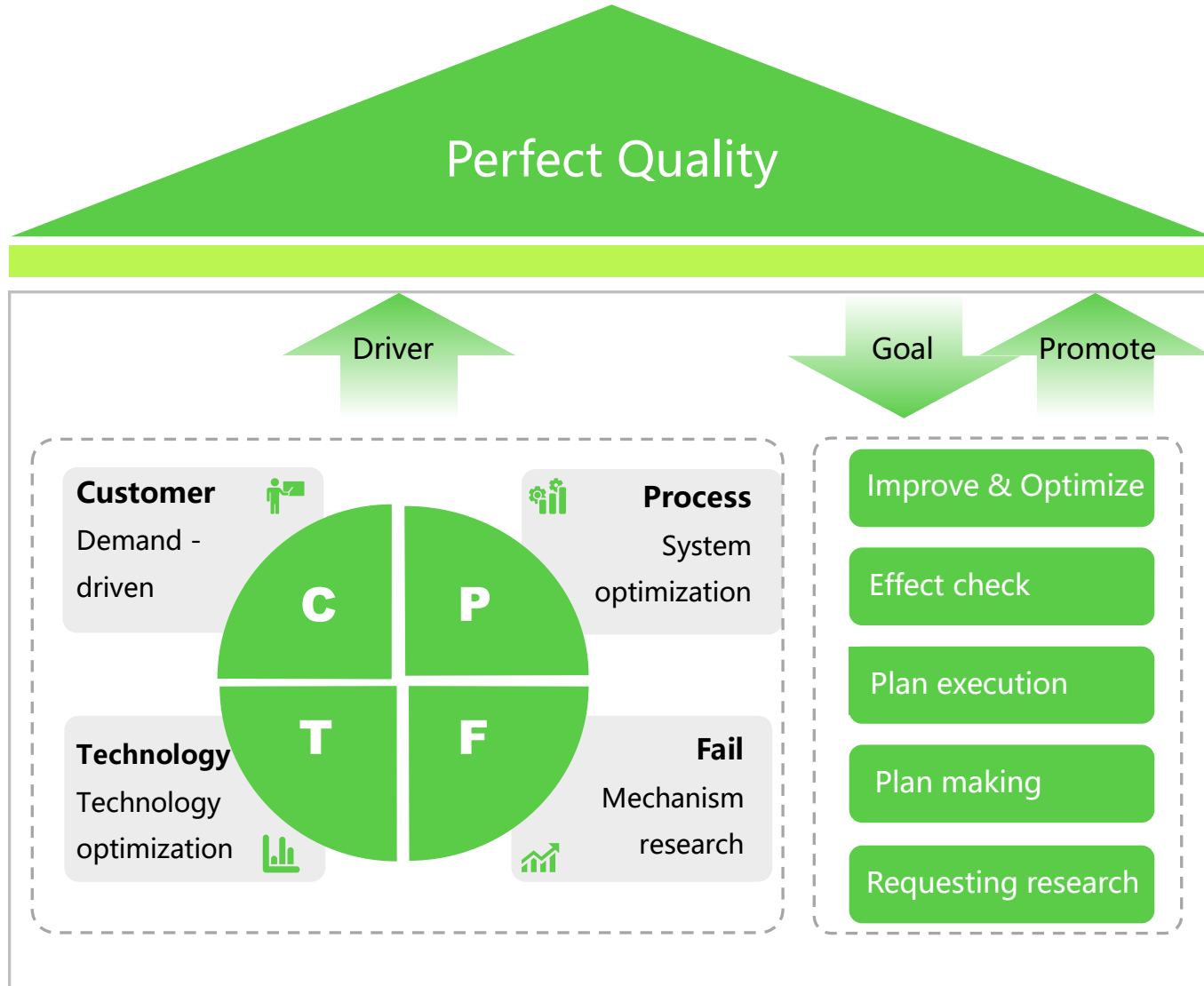

## Company's Quality Goals

Improve the quality management system continuously, adjust and expand it in time according to the needs of the company's development.

- Serious customer complaints of quality accidents **0** time
- Process defect rate **≤0.3%**
- Product delivery achievement rate **≥95%**



## Design Quality Goals

- New technology innovation **≥3** items/year  
(Technological innovation R&D, process innovation and improvement.)
- Design error rate **≤1** time/year
- Design verification success rate of mass production projects **≥100%**



## Service Quality Goals

- Customer complaints **≤5** times
- Customer satisfaction **≥98%**





# Development Goal

## 2020~2024 sales target and strategic target

(Unit: ten thousand yuan)







**THANKS**